

Overview

LC-MS is the preferred technique for bioanalysis in drug metabolism pharmacokinetic (DMPK) studies. Major pharmaceutical companies collectively process hundreds of thousands of samples per week in this area. Therefore, the need to increase sample throughput without compromising sensitivity remains pressing. Pooling of multiple streams of LC eluates for MS analysis has the undesirable effect of diluting the analytes. Staggering sample injections and scheduling the sampling of the LC stream by the mass spectrometer could become complicated especially when fast LC is used. Other techniques such as MUX™ may degrade sensitivity thus affecting quantitation.

Coupled to the need for higher throughput, lower sample and buffer consumptions have also become more desirable both for economic and environmental reasons. Multidimensional splitless microflow pumps and chromatographic resins that achieve very high efficiency and thus high sensitivity are now commercially available. This report presents a new high utility multiplexed microLC-MS source to perform high throughput quantitation for ADME studies by taking advantage of the low flow rates and also incorporating the newly available components for high sensitivity microflow LC-MS. The source will be used in conjunction with a dual arm 4-injector port autosampler and DiscoveryQuant software for MRM data acquisition and management. The integrated system enables a practical high throughput solution (30 s-45 s per injection for gradient elution) to ADME applications that require more demanding chromatographic separations than the basic trap-and-elute approach.

Multiplexed LC-MS sources

I. Existing commercially available sources with multiple LC inlets

- ESI and APCI inlets in the same source, but only one is used at any one time (AB SCIEX Duo Spray)
- Two fixed ESI emitters are present and can be used simultaneously. There is no independent position adjustment for each inlet (AB Sciex “Cobra”)
- Four to Eight LC inlets with a rotating input into the mass spectrometer (Waters “MUX” Technology)
- A variety of experimental multiplexed LC sources ^{1,2} mainly for nanospray-MS.

II. The multi-function, multiplexed LC-MS source for DMPK studies

A. Requirements

- Two ESI inlets expandable to four ESI inlets are accommodated in the same source
- Simultaneous sprays from two or more inlets
- Balanced inputs from each spraying inlet
- Microflow regime, i.e., 20 µL-200 µL/min
- Desolvation mechanisms

B. Design

Because of the possibility of interference from simultaneous sprays which may dramatically attenuate the MS signal from one ESI inlet vs. the other, exceptional flexibility of the positioning mechanism of the ESI emitters must be built into the source. By tilting the spray emitter away from the orthogonal position toward the on-axis position, more signal can be sent into the mass spectrometer to potentially compensate for signal loss due to spray interference. For the microflow regime used in this study, off-orthogonal spray should be feasible without fear of overwhelming the MS detector.

- Four ESI spray emitters in a circular pattern in a plane orthogonal to the MS inlet orifice
- The spray tip has a 65-100 µm i.d. and a 280-360 o.d.
- Spray tips with the ends ground to a thin edge (sculptured) to reduce the spraying from the peripheral of the tip were tested against conventional flat-ended tips
- Each ESI inlet has its own 3-D positioning mechanism for optimizing spray
- One or more of the ESI inlet can be tilted from the orthogonal position to increase MS signal input
- Desolvation using heated gas

Source Design

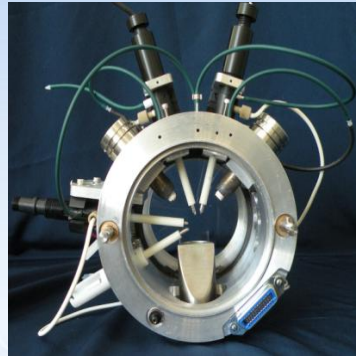
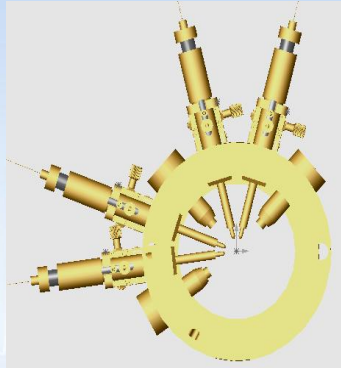

3-D model of the multi-functional multiplexed LC-MS source

- The top two emitters are intended for simultaneous microLC-MS. These two emitters can be tilted by up to 25° away from orthogonal to increase MS signal intensity
- The third emitter on the left is intended for single- input conventional LC-MS
- The fourth emitter on the left is intended for flow injection analysis

The multiplexed LC-MS source constructed to be compatible with an AB Sciex 4000 QTRAP

The third heater has not been installed in this source

I. ESI Emitters



Conventional ESI flat-ended spray tip, 65 µm to 150 µm i.d stainless steel tubing



This source – “sculptured” spray tip 65 µm to 100 µm i.d. stainless steel tubing

II. Heaters for desolvation gas

Two types of heaters were used.

1. The AB Sciex ceramic heaters in the Turbo V source.
2. A ceramic heater capable of heating up to 600° C. Gas (nitrogen) conduits were built into the heaters.

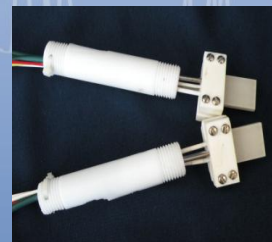

The ESI emitter comprises the following:

- 65-100 µm i.d. stainless steel tubing, the end of which is the spray tip
- Sheath gas tube with a tapered end
- Ceramic cover for electrical and thermal insulation
- PEEK casing for electrical isolation. The two parts of the PEEK case also slide against each other to allow Z- movement of the emitter-tip/sheath gas assembly with respect to the mass spectrometer inlet orifice
- An internal spring-loaded mechanism for adjusting the position of the spray tip with respect to the sheath gas tube opening.

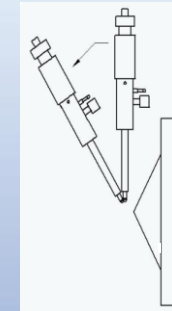

The emitter can be tilted by up to 25°. The more consistent axial spray of the sculptured tip appeared to produce better sensitivity when tilted from orthogonal than the flat-cut tip.

15 mm x 25mm flat ceramic heaters (up to 600° C) with internal gas conduits have small footprints and can be placed conveniently between emitters or directly in front of the MS inlet orifice.

Source Performance Testing - Simultaneous LC-MS from 2 ESI emitters

LC Methods:

A: H₂O/0.2% formic acid, B: ACN

Gradient program:

Time/minute	A %	B %
0	80	20
0.7	20	80
0.8	20	80
0.9	80	20

Flow rate: 75 µL/min/

Column: C18 Halo 0.5 mm i.d., 3-5 cm long

Pump: 2-D Eksigent HT Express splitless (up to 8,000 psi)

Samples:

Inlet 1: Verapamil (455.4/165.2), 0.05 µM, **red trace**
Buspirone (386.3/122.1), 0.05 µM, **blue trace**

Inlet 2: Prazosin (384.5/247.2), 0.05 µM **green trace**
Diltiazem (415.3/178.1), 0.05 µM **grey trace**

Sample injection: Custom-built dual arm 4-injector port autosampler.

- 5 µL injection loop
- The injections and gradients for inlet 1 and inlet 2 were staggered by 30 seconds.

Mass spectrometer: AB Sciex 4000 Triple quad running multiple Reactive Monitoring (MRM), 50 -100 ms dwell time per channel
Sheath gas: 20 psi
Heater temperature: 600° C
Heater gas: 40 psi

Results

I. Flat-Cut Tip vs. Sculptured Tips

a) Peak Shape (orthogonal position)

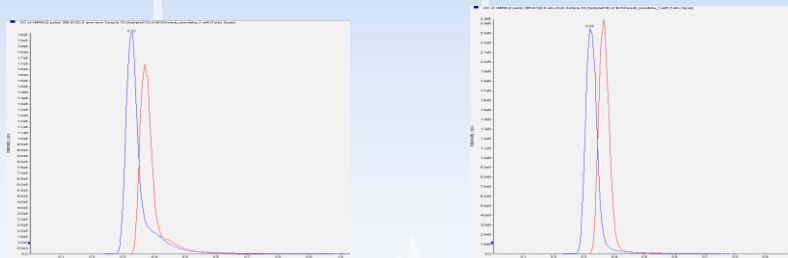

b) MS response improvement with a 25° tilt from orthogonal

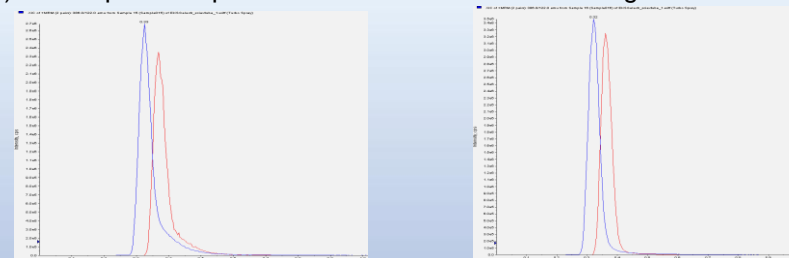

- Peak tailing was more often observed with sprays from the conventional flat-cut tip. With the sculptured tip, peaks with full width of 5-6 s were consistently observed.
- When the spray emitter was tilted toward the MS inlet orifice by 25°, MS sensitivity increased by ~50% with the sculptured tip spray and only about 25% with the flat-cut tip. The axial spray of the sculptured tip was easier to maneuver than the flat-cut tip which often showed spray centers from the edge of the flat-cut end.
- The improved response of the off-orthogonal spray may be used as an extra parameter for balancing the MS response from multiple ESI inlets.

Results

ii. Simultaneous sprays from two ESI emitters

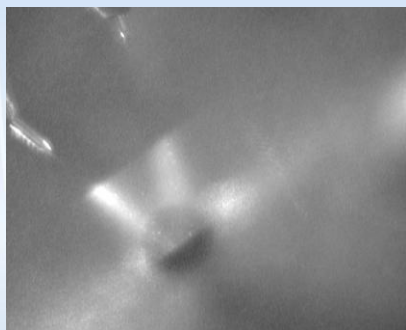

The sprays from the top two ESI emitters were simultaneously directed toward the MS inlet orifice. The optimization of the spray positions to minimize spray interference was conveniently visualized with the camera and the sprays illuminated by a focused laser beam even though the best MS response did not necessarily correspond to the best visual overlap with the MS inlet orifice probably because the viewing angle of the camera may not have been optimized.

iii. High throughput, high efficiency simultaneous gradient separations of small molecules for quantitation

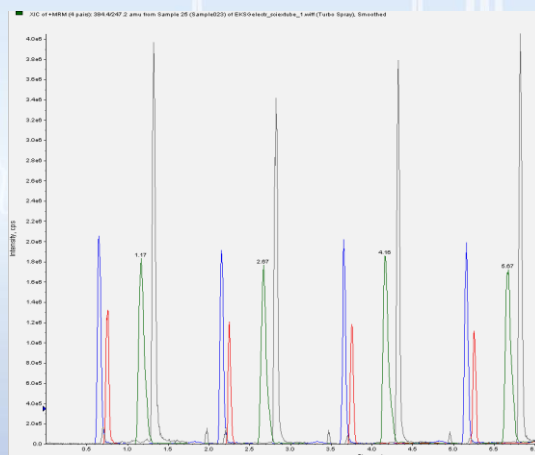

Prazosin=green
Diltiazem=grey
Buspirone=Blue
Verapamil=Red

Equivalent responses for quantitation from two simultaneous microLC-MS elutions were obtained with spray emitters properly positioned. 8 injections of two 1-minute gradient separations of two analytes each were achieved in under 6 minutes. The gradients were staggered by 30 seconds for display purposes, but was not necessary,

Summary

- A multiplexed ESI source with two spray emitters for simultaneous microLC-MS for MRM quantitation, and two additional emitters for other functions has been designed, constructed and tested.
- The ability to tilt the spray emitter out of the orthogonal plane, and the use of sculptured spray tips provided improved flexibility and ease for balancing the MS response for the simultaneous sprays.
- Multiple injections of 1-minute gradient separations of multiple analytes with good resolution and equivalent responses for both LC inlets were demonstrated.
- Preliminary integration of the multiplexed ESI source with a 2-D splitless LC pump, a dual-arm multiple injector-port autosampler, and the DiscoveryQuant software for data acquisition and management showed that the approach should be practical for creating a highly flexible platform for high throughput applications in ADME quantitation.